

Instruction Manual

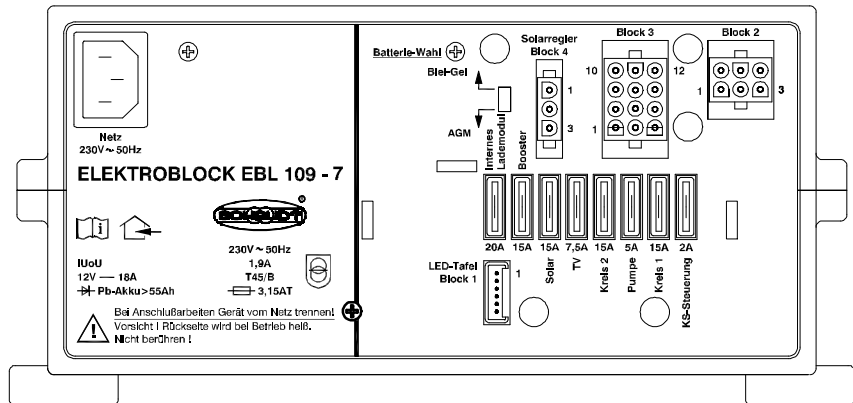

Electroblock EBL 109-7

Table of contents

1	Introduction	2
2	Safety information	2
2.1	Meaning of safety symbols	2
2.2	General safety information	2
3	Application and function	3
3.1	Battery functions	5
3.2	Additional functions	6
4	Design	6
5	Operation	7
5.1	Starting up the system	7
5.2	Changing the battery	8
5.3	System faults	9
5.4	Switching off the system	10
5.5	Closing down the system	10
6	Maintenance	11
	Appendix	12

1 Introduction

This instruction manual contains important information on the safe operation of equipment supplied by Schaudt. Make sure you read and follow the safety instructions provided.

The instruction manual should be kept in the vehicle at all times. Ensure that other users are made aware of the safety regulations.

2 Safety Information

2.1 Meaning of safety symbols



▲ **DANGER!**

Failure to heed this warning may result in death or serious injury.



▲ **WARNING!**

Failure to heed this warning may result in personal injuries.



▲ **ATTENTION!**

Failure to heed this warning may result in damage to the device or connected consumers.



▲ This symbol indicates recommendations or special features.

2.2 General safety information

The device is state-of-the-art and complies with approved safety regulations. Nonetheless, personal injuries or damage to the device may occur if the safety instructions contained herein are not followed.

Ensure that the device is in perfect working order before use.

Any technical faults which may impact personal safety or the safety of the device must be rectified immediately by qualified personnel.



▲ **DANGER!**

230 V mains voltage carrying parts.

Danger of death due to electric shock or fire:

- The electrical system of the motorhome or caravan must comply with current DIN, VDE and ISO regulations.
- Never modify the electrical system.
- Never modify the device.
- Only qualified electricians are permitted to carry out electrical connection work in accordance with the installation instructions supplied by Schaudt.
- Connection work should only be carried out when the system is completely de-energised.
- Never try to start the device using a defective mains cable or with a faulty connection.
- Never carry out maintenance work on live devices.



▲ DANGER!

Incorrect installation!

Electric shock or damage to connected devices:

- Install as shown in the installation instructions.
- The mains connection line may only be replaced by an authorised customer service department or by qualified persons.



▲ WARNING!

Hot components!

Burns:

- Blown fuses should only be replaced once the system has been completely disconnected from the power supply.
- Only replace blown fuses once the cause of the fault has been identified and rectified.
- Never bypass or repair fuses.
- The rear of the device may become hot during operation. Do not touch.
- Only use original fuses rated as specified on the device.

3 Application and function



- ▲ This device is not intended to be used by persons (including children) with limited physical, sensory or mental aptitude or lack of experience and/or knowledge unless they are supervised by a person responsible for their safety or have received instruction from this person as to how the device is used.

Children are to be supervised so as to ensure they do not play with the device.

This device is intended for installation into a vehicle.

The EBL 109-7 electroblock is the central power supply unit for all 12 V consumers connected to the electrical system of the caravan. It is usually located in a cupboard or storage area and is accessible from the front in order to change fuses.

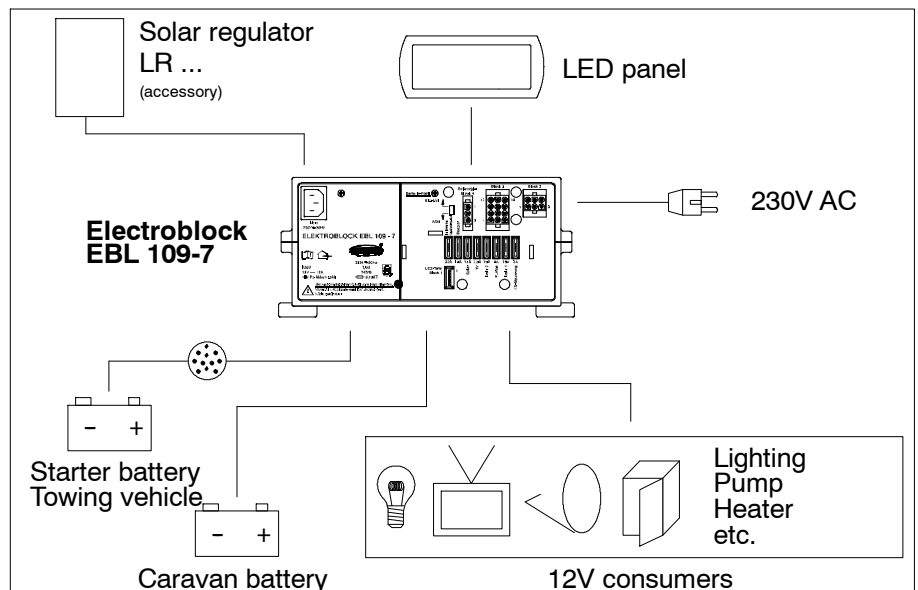

Fig. 1 On-board power supply system

The electroblock has been designed solely for connecting up to a 12 V on-board supply.

Restricted operation is also possible without a battery being connected.

Connected units can be supplied from the caravan battery or the towing vehicle's battery if a mains supply is not available.

Modules The EBL 109-7 electroblock comprises of:

- a charge module for charging all connected batteries
- the complete 12 V distribution
- fuses for the 12 V circuits
- a battery booster

System devices An LT ... control and switch panel must be connected up to run it. These devices control the electrical functions in the caravan's living area as well as the accessories.

Connection options for a solar charger and a solar-cell module have been provided.

Flat vehicle fuses protect the various circuits.

Protective circuits

- Excess temperature
- Overload
- Short circuit

Mains connection 230 V AC \pm 10%, 47 to 63 Hz sinusoidal, protection class I

Current-carrying capacity 12 V outputs may be loaded with max. 90% of the rated current of the respective fuse (see also installation instructions or front panel).

Max. total current All the combined consumers should not exceed the following load:

- Mains operation:
 - With battery 25 A
 - Without battery 18 A
- Operation with towing vehicle, ignition ON
 - 8 A

3.1 Battery functions

Suitable batteries	6-cell AGM or lead gel batteries, 55 Ah and above.	
Battery charging whilst moving	Charging the caravan battery whilst driving; increasing the supply voltage coming from the towing vehicle via the battery booster.	
Main battery switch	<p>The primary battery switch on the LT ... instrument and control panel isolates all 12 V consumers from the caravan battery (exception: the fridge controller electronics).</p> <p>This prevents the caravan battery from being slowly discharged by standby currents.</p> <p>The batteries can continue to be charged using the electrobloc, the towing vehicle or the solar charger, even when the main battery switch is off.</p>	
Battery selector switch	The switching option provided by the battery selector switch ensures optimum charging of the two battery types, lead gel and AGM.	
Automatic disconnecter	All consumers are automatically switched off when the ignition is turned on when the caravan is connected to the towing vehicle.	
Battery alarm	<p>A red LED on the LT ... control and switch panel starts to flash when the battery voltage drops below 11.0 V.</p> <p>The caravan battery is always fully recharged as quickly as possible. For more information, see the "Battery voltages" table in the instruction manual for the relevant LED panel.</p>	
Standby current from towing vehicle battery	No standby current; additional current consumption by the fridge's control electronics (see documentation supplied by the fridge manufacturer); measured when all of the consumers inside the caravan are switched off	
Battery charging via mains connector	<p>Caravan battery</p> <p>Characteristic charging curve</p> <p>End of charge voltage</p> <p>Charging current</p> <p>Voltage for float charge</p>	<p>IUoU</p> <p>Lead gel: 14,4 V / AGM: 14,7 V</p> <p>18 A</p> <p>13.8 V with automatic switch function</p>

3.2 Additional functions



▲ ATTENTION!

Avoid continual operation at 12 V because total discharge damages the caravan battery.

Refrigerator controller This output supplies the control electronics of a fridge:

- From the caravan battery
- From the towing vehicle's battery when the ignition is switched on
- From the mains supply when it is connected up
- From a solar panel (via the regulator) if one is connected.

Battery charging with solar charging regulator Maximum permitted charge current 14 A, protected with 15 A

4 Layout

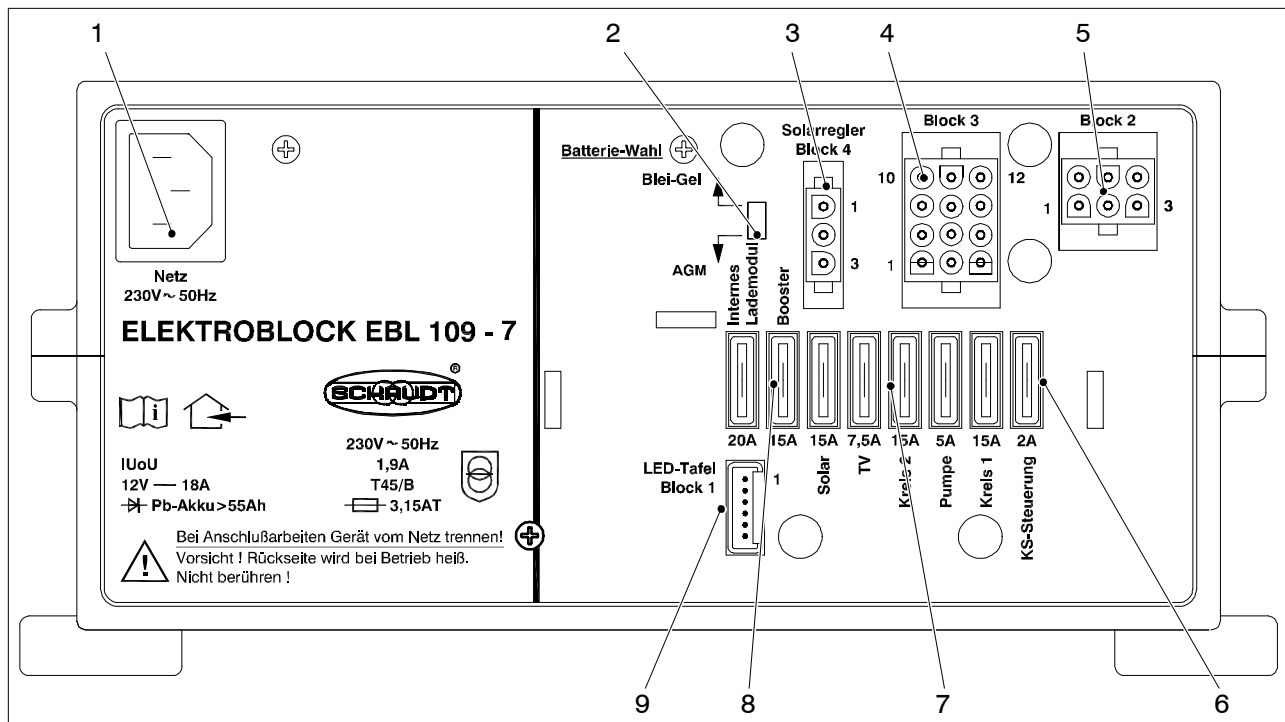

Fig. 2 Front view of EBL 109-7 Electrobloc

- 1 Mains connector
- 2 Battery selector switch for lead-gel/AGM
- 3 Connectors BL. 4 Solar charge regulator LR ...
- 4 Connectors BL. 3 Consumers
- 5 Connectors BL. 2 Batteries, vehicle
- 6 Flat vehicle fuse for fridge controller
- 7 Flat vehicle fuses for consumers
- 8 Flat vehicle fuses for internal modules
- 9 Connectors BL. 1 for LT control and switch panel

5 Operation

The electrobloc is operated from the LED panel connected.

The EBL 109-7 electrobloc does not need to be operated for daily use.

One-off configuration is only required after the type of battery (AGM or lead-gel) has been changed, during commissioning or when upgrading with accessories (see section 5.2 and the installation instructions for the EBL 109-7 for details).

5.1 Starting up the system



**12 V main switch
(on LT ... control and
switch panel)**

▲ ATTENTION!

Ensure that the battery selector switch (Fig. 2, Pos. 4) is set to the correct position for the battery installed. If it is not, damage to the battery or connected devices can result.

- ▶ Switch on the main battery switch on the LT ... control and switch panel (see instruction manual for the relevant panel).

The main 12 V switch (see instruction manual for the relevant control and switch panel) switches on and off all consumers and the control and switch panel (exception: the fridge controller electronics).

For more information, see the instruction manual for the LED panel.

**Generator operation and
passenger vehicle ferries**



▲ ATTENTION!

The electrobloc, 12 V consumers and the connected devices can be damaged if the thresholds for the 230 V supply are exceeded. So therefore:

- Do not connect a generator until it is running smoothly.
- It is essential that the generator conforms to the specifications of the mains supply.
- Do not connect the electrobloc to the mains supply on board passenger vehicle ferries (a correct mains supply is not always guaranteed on board these ferries).

**Operation with solar
regulator**



▲ ATTENTION!

Do not operate a solar regulator without battery connected. There is no battery backup function in this case. This can lead to damage to the devices connected.

Operation at the towing vehicle



▲ ATTENTION!

Switch off the ignition when the towing vehicle is stationary (otherwise consumers are powered by the towing vehicle battery). This can lead to discharging of the starter battery – the towing vehicle can then no longer start.

5.2 Changing the battery



▲ ATTENTION!

Use of incorrect battery types or incorrectly rated batteries.
Damage to the battery or devices connected to the electrobloc:

- Batteries should only be changed by qualified personnel.
- Follow the battery manufacturer's instructions.
- Only connect the electrobloc to 12 V power supplies with rechargeable 6-cell lead gel or AGM batteries. Never use non-approved battery types such as NiMH batteries.

▲ Normally only batteries of the same type and capacity should be used, i.e. the same as those installed by the manufacturer.

Changing the battery

▶ Disconnect the battery from the electrobloc by disabling the main battery switch on the LT ... control and switch panel (see section 5.5).

▶ Unhitch the caravan from the towing vehicle.

▶ Replace battery.

▶ After changing the battery, recheck which type of battery has been inserted.



▲ DANGER!

An incorrect battery selector switch can represent a risk of explosion through a build-up of explosive gases so ensure the battery selector switch is set to the correct position.



▲ ATTENTION!

An incorrect battery selector switch setting can result in damage to the battery.

▶ Disconnect the electrobloc from the mains before adjusting the battery selector switch.

▶ Move the battery selector switch (Fig. 2, Pos. 4) to the correct position using a thin object (e.g. a ballpoint pen):

- Lead gel battery: Set the battery selector switch to "Lead-gel".
- AGM battery: Move the battery selector switch to "AGM".

Starting up the system

▶ Start up the system as described in Section 5.1.

5.3 System faults

Flat vehicle fuses

A fault in the power supply system is usually caused by a blown fuse.

Please contact our customer service address if you cannot rectify the fault using the following table.

If this is not possible, e.g. if you are abroad, you can have the electrobloc repaired at a specialist workshop. Please note that the warranty becomes void if incorrect repair work is carried out. Schaudt GmbH can not accept liability for any damages resulting from such repairs.

Fault	Possible cause	Remedy
Caravan battery is not charged during 230 V operation (battery voltage permanently below 13.3 V)	No mains voltage	Switch on the automatic circuit breaker in the vehicle; check the mains voltage
	Defective electrobloc	Contact the customer service department
Caravan battery overloaded during 230 V operation	Defective electrobloc	Contact the customer service department
Caravan battery is not charged whilst driving	Defective alternator	Check the alternator
	No voltage applied to "Ignition ON" input or permanent plus	Check the fuse and wiring Check the towing vehicle plug connection
	Defective electrobloc	Contact the customer service department
Caravan battery is overloaded whilst driving	Defective electrobloc (booster)	Contact the customer service department
Solar charger is not working (mains supply off)	Solar charge regulator not plugged in	Plug in solar charge regulator
	Defective fuse or wiring	Check fuse and wiring
	Solar charge regulator defective	Check solar charge regulator
12 V supply does not work in the living area	12 V main switch for caravan battery is switched off	12 V main switch for caravan battery must be switched on
	Defective fuse or wiring	Check fuse and wiring
	Voltage applied to "Ignition ON" input	Switch ignition off
	Defective electrobloc	Contact the customer service department
The electrobloc cannot be operated from the LT ... control and switch panel.	Defective electrobloc	Contact the customer service department
	Defective LT ... control and switch panel	Contact the customer service department



- ▲ The charging current is reduced automatically if the device becomes too hot due to excessive ambient temperature or lack of ventilation. Always prevent the device from overheating nevertheless.
- ▲ The caravan battery must be fully recharged if the battery alarm is activated (LED on the control and switch panel flashes).

5.4 Shutting down the system

- ▶ Move the main battery switch on the LT ... control and control panel to OFF (see operating instructions for the control and switch panel).

5.5 Closing down the system



▲ ATTENTION!

Fully charge the caravan battery before and after closing down the system. Connect a vehicle with an 80 Ah battery and a vehicle with a 160 Ah battery to the mains for at least 12 and 24 hours respectively. A battery which is not fully charged may discharge fully (and hence be damaged) if not used for longer periods.



▲ ATTENTION!

Connected consumers can be damaged on exceeding the input voltages permitted. So therefore:

- Do not operate any connected Schaudt solar charge regulator without battery.
- When the battery is changed or removed, first unplug the "+ solar cell" connector on the solar charge regulator.

Closing down the system for up to 6 months

- ▶ Fully charge the caravan battery before closing down the system.

The caravan battery is then protected against total discharge. This only applies if the battery is intact. Follow the battery manufacturer's instructions.

Closing down the system for more than 6 months

- ▶ Fully charge the caravan battery before closing down the system.
- ▶ Remove the clamps from the battery terminals.
- ▶ Remove the "+ solar cell" connector on the solar charge regulator.

6 Maintenance

The EBL 109-7 electroblock requires no maintenance.

Cleaning Clean the electroblock with a soft, slightly damp cloth and mild detergent. Never use spirit, thinners or similar substances. Do not allow liquids to enter the electroblock.

© No part of this manual may be reproduced, translated or copied without express written permission.

Appendix

A EC Declaration of Conformity

Schaudt GmbH hereby confirms that the design of the EBL 109-7 complies with the relevant regulations.

The original EU conformity declaration is available and can be referred to at any time.

Manufacturer Schaudt GmbH, Elektrotechnik & Apparatebau

Address Planckstrasse 8
88677 Markdorf
Germany

B Special fittings/accessories

Solar charge regulator Schaudt solar charger LR ... model for solar modules with a total current of 14 A, including 0.5 m connection cable and connector plug

Cover The fuses are behind the blue cover marked FUSE. These can be ordered separately (type. no. 106.120).

C Customer service

Customer service address Schaudt GmbH, Elektrotechnik & Apparatebau
Planckstraße 8
D-88677 Markdorf

tel.: +49 7544 9577-16

email: kundendienst@schaudt.gmbh

web: www.schaudt.gmbh

Send in the device Returning a defective device:

- ▶ Always use well padded packaging.
- ▶ Fill in and enclose the fault report, see Appendix D.
- ▶ Send it to the addressee (free of charge).

D Fault report

In the event of damage, please return the defective device together with the completed fault report to the manufacturer.

Device type: _____
 Item no.: _____
 Vehicle: _____
 Manufacturer: _____
 Model: _____
 Own installation? Yes No
 Upgrade? Yes No

There is the following defect:
 (please select)

no Battery-charge during mains operation					
no Battery-charge during mobile operation		Tank		Voltage	
The following electrical consumers do not work:					
Control and switch panel does not work correctly					
Permanent fault					
Intermittent fault/loose contact					

Other remarks:

E Block diagram/wiring diagram

* 9 10

Connections 9 and 10 must be fused externally in the vehicle up to a maximum of 15 A.

* ...

The trailer hitch pin assignment of the towing vehicle/caravan connector complies with EN 1648-1

